

客 戶  
CUSTOMER:

科领表计

## 送 樣 承 認 書

### Crystal Resonator datasheet

產 品 名 稱

DESCRIPTION : Quartz Crystal Resonator 3225SMD-4pin

產品型號 / 料號

PART NO: 13.1072MHz/ BD3A4013107210

客 戶 料 號

Client NO: 300017

送 樣 日 期

DATE: 2023-5-17

供應商審核 Confirmed By Ourself			客戶確認 Client Confirmed		
品質 Quality	研發 R/D	公章 Cachet	測試	審核	核准
刘媛	杜红光				



BD CRYSTAL

供應商: 深圳市北迪荣昌电子有限公司

MANUFACTURE: SHENZHEN BDRC ELECTRONICS CO., LTD

公司地址: 深圳市宝安区石岩街道园岭石环路 118 号新永丰第二工业区 1 栋六楼

ADD: Floor 6, building 1, Xinyongfeng No.2 Industrial Zone, No.118, Yuanling Stone Ring Road, Shiyan street, Bao'an District, Shenzhen

TEL: +86-0755-86212103 FAX: +86-0755-86212112

手机: 13480903123 李火星

<http://www.xabdrc.com> Email: XABDRC@163.com

<b>深圳市北迪荣昌电子有限公司</b> <b>SHENZHEN BDRG ELECTRIC CO.,LTD</b>	北 迪 P/N	BD3A4013107210	
<b>3225 石 英 晶 体 谐 振 器</b> <b>Specification of quartz crystal</b>	客 户 P/N		
	VER	01	PAGE 2/8

## 目 录

### CONTENT

规 格	页次
SPECIFICATIONS	PAGE

1、技术参数 ELECTRICA SPECIFICATIONS	3
2、机械特性 MECHANICAL CHARACTERISTICS	4
3、外形尺寸丝印 OUTLINE & DIMENSION&MARKING	5
4、内部结构 BYELAW	6
5、编带卷盘 Type&Reel	7
6、编带方式 TAPING METHOD	8

深圳市北迪荣昌电子有限公司 SHENZHEN BDRG ELECTRIC CO.,LTD	北 迪 P/N	BD3A4013107210	
3225 石 英 晶 体 谐 振 器 Specification of quartz crystal	客 户 P/N		
	VER	01	PAGE 3/8

## 1、技术参数 ELECTRICAL SPECIFICATIONS

1	标称频率 Nominal frequency	13.1072 MHz
2	振荡模式 Mode of vibration	基频 AT Fundamental
3	负载电容 Load capacitance	10.0pF
4	调整频差 Frequency tolerance	±10ppm(25±5℃)
5	工作温度频差 Frequency temperature characteristics	±20ppm(-20℃to+70℃)
6	谐振电阻 Equivalent series resistance	50 Ω max
7	静 电 容 Shunt capacitance	5.0pF max
8	绝缘电阻 Insulation resistance	500MΩmin./100±15VDC
9	激励电平 Drive level	10μw
10	老 化 率 Aging	±3ppm/year
11	贮存温度 Storage temperature range	-55℃to +125℃
12	测试仪器 Test Impedance Meter	S&A 250B
13	印字标志 Marking	13.1072 MHZ

深圳市北迪荣昌电子有限公司 SHENZHEN BDRG ELECTRIC CO., LTD	北 迪 P/N	BD3A4013107210	
3225 石英晶体谐振器 Specification of quartz crystal	客 户 P/N		
	VER	01	PAGE 4/8

## 2、机械特性 MECHANICAL CHARACTERISTICS

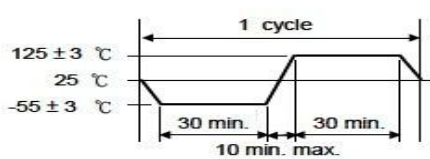
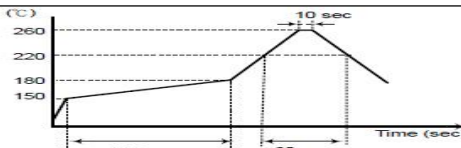
NO.	测试项目 Test item	测试方法 Test Method	
1	跌落 Shock	高度 100cm 自由跌落到硬地板上 3 次。 100cm height, fall freely onto hardwood surface 3 times.	$\Delta f/f \leq \pm 5\text{ppm}$ $\Delta R \leq 15\%$
2	机械冲击 mechanical shock	Device are shocked to half sine wave(1000 G)three mutually perpendicular axes each 3 times.0.5m sec.duration time	$\Delta f/f \leq \pm 5\text{ppm}$ $\Delta R \leq 15\%$
3	振 动 Vibration	频率 Frequency: 10-2000Hz 峰值 Amplitude : 1.52mm/20G 周期 Cycle time : 20min (10-55-10 Hz) 方向 Direction : 4 hours (Total test time 12 hours)	$\Delta f/f \leq \pm 5\text{ppm}$ $\Delta R \leq 15\%$
4	可 焊 性 Solderbility	温度 Temp.: $260 \pm 5^\circ\text{C}$ 时间 Time : $5 \pm 1\text{s}$ 效果 Effect : 0.5mm minimum 处理 Flux: Rosin resin methyl alcohol solvent(1: 4)	Check by Microscope AtLeast95%Coated (MIL-STD-883E).
5	高温特性 Heat Resistant	温度 Temperature : $+125^\circ\text{C} \pm 3^\circ\text{C}$ 时间 Time : 500 h $\pm 12$ hours.	$\Delta f/f \leq \pm 5\text{ppm}$ $\Delta R \leq 15\%$
6	低温特性 Cold resistant	温度 Temperature : $-40 \pm 3^\circ\text{C}$ 时间 Time : 500 h $\pm 12$ hours.	$\Delta f/f \leq \pm 5\text{ppm}$ $\Delta R \leq 15\%$
7	冷热循环 Cold & Heat Cycle Test	Total 100 cycles of the following temperature cycle 	$\Delta f/f \leq \pm 5\text{ppm}$ $\Delta R \leq 15\%$
8	稳态湿热 Humidity Resistant	温度 Temperature : $85 \pm 3^\circ\text{C}$ 湿度 Humidity : 90-95% RH 时间 Time : 500 h	$\Delta f/f \leq \pm 5\text{ppm}$ $\Delta R \leq 15\%$
9	回流焊 Reflow		$\Delta f/f \leq \pm 5\text{ppm}$ $\Delta R \leq 15\%$

深圳市北迪荣昌电子有限公司 SHENZHEN BDRG ELECTRIC CO., LTD	北 迪 P/N		BD3A4013107210	
3225 石 英 晶 体 谐 振 器 Specification of quartz crystal	客 户 P/N			
	VER	01	PAGE	5/8

### 3、外形尺寸丝印 OUTLINE & DIMENSION&MARKING (UNIT: mm)

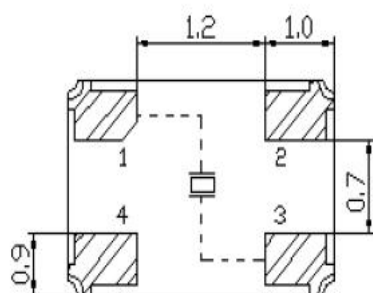
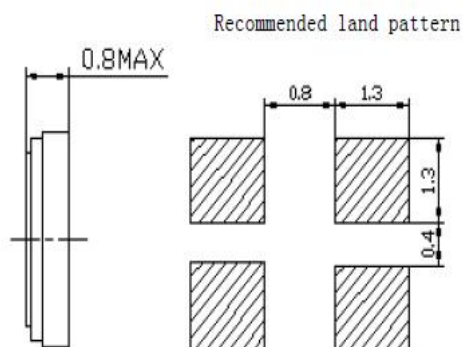
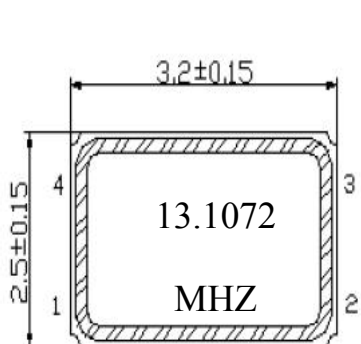

NOTE: Pin#2 and #4 are connected through cover, in case connected to GND. Frequency might be drifted.

深圳市北迪荣昌电子有限公司 SHENZHEN BDRG ELECTRIC CO., LTD	北 迪 P/N	BD3A4013107210	
3225 石 英 晶 体 谐 振 器 Specification of quartz crystal	客 户 P/N		
	VER	01	PAGE 6/8

#### 4、 内部结构 BYELAW

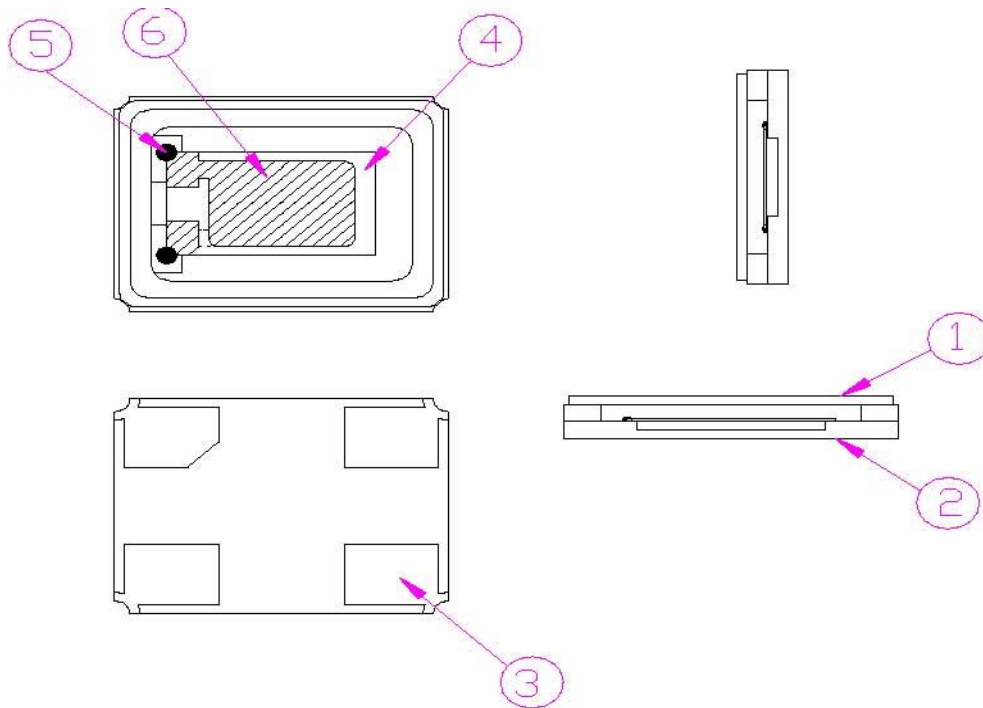

#### Material List

NO	COMPONENTS	MATERIALS	QTY	FINISH/SPECIFICATIONS
1	Cap(Lid)	Metal(Fe)	1	-
2	Base(Package)	Ceramic(Al <sub>2</sub> O <sub>3</sub> )	1	Alumina ceramics
3	PAD(Package)	Au	4	Tungsten metalize +Ni plating +Au plating
4	Crystal blank	SiO <sub>2</sub>	1	-
5	Conductive adhesive	Ag	4	Silicone resin
6	Electrode	Ag + Cr	2	-

深圳市北迪荣昌电子有限公司 SHENZHEN BDRG ELECTRIC CO., LTD	北 迪 P/N	BD3A4013107210	
3225 石 英 晶 体 谐 振 器 Specification of quartz crystal	客 户 P/N		
	VER	01	PAGE

### 5、编带卷盘 Type&Reel

1. 每一内盒装: 3000 PCS (1×reel);
2. 每一外盒装: 30000 PCS (10×inner box).
3. 编带尺寸:

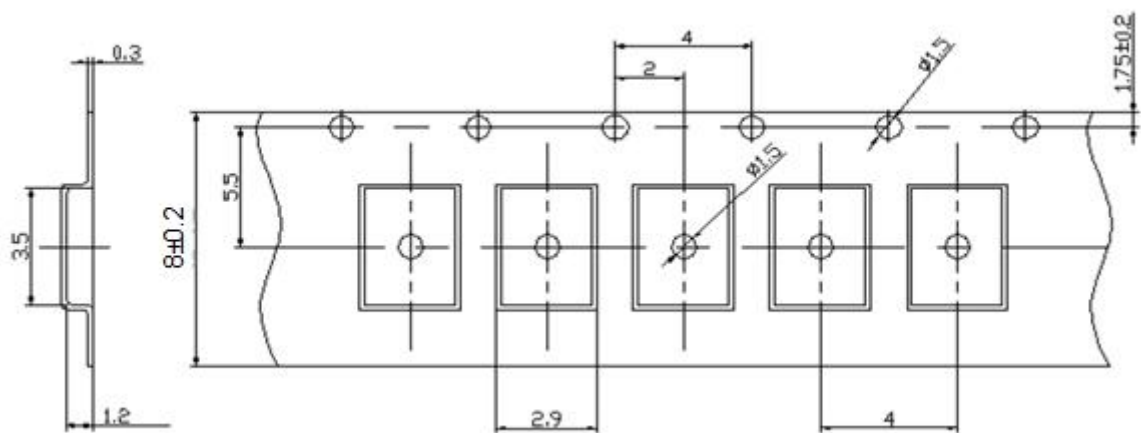

#### ■ 轮 (REEL)

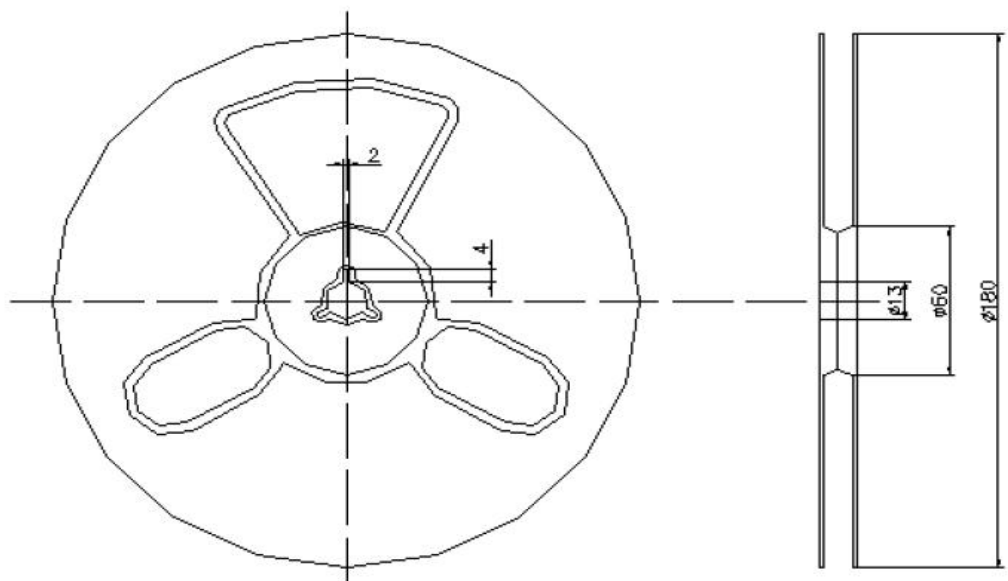

深圳市北迪荣昌电子有限公司 SHENZHEN BDRG ELECTRIC CO., LTD	北 迪 P/N	BD3A4013107210	
3225 石 英 晶 体 谐 振 器 Specification of quartz crystal	客 户 P/N		
	VER	01	PAGE

## 6、编带方式 TAPING METHOD

